

PROPRIETARY AND CONFIDENTIAL

THE INFORMATION CONTAINED IN THIS DRAWING IS THE SOLE PROPERTY OF DYTRAN INSTRUMENTS INC. ANY REPRODUCTION IN PART OR AS A WHOLE WITHOUT THE WRITTEN PERMISSION OF DYTRAN INSTRUMENTS INC. IS PROHIBITED

REVISIONS

REV.	ECN	DESCRIPTION	BY/DATE	CHK	APPR
A	14614	INITIAL RELEASE. SAME AS REV X1.	KG 12/01/20	RA	DV

VARIATION TABLE

MODEL	SENSITIVITY
3055D7T	100mV/g
3055D8T	50mV/g
3055D9T	20mV/g
3055D10T	10mV/g
3055D13T	200mV/g
3055D14T	500mV/g

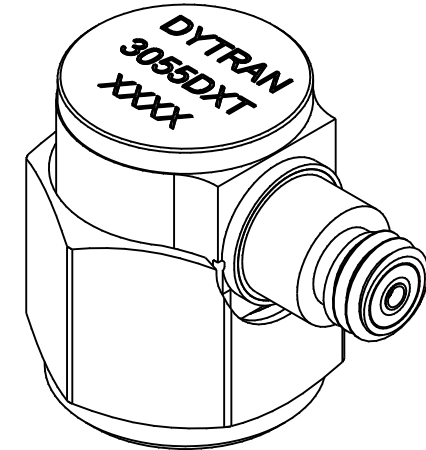
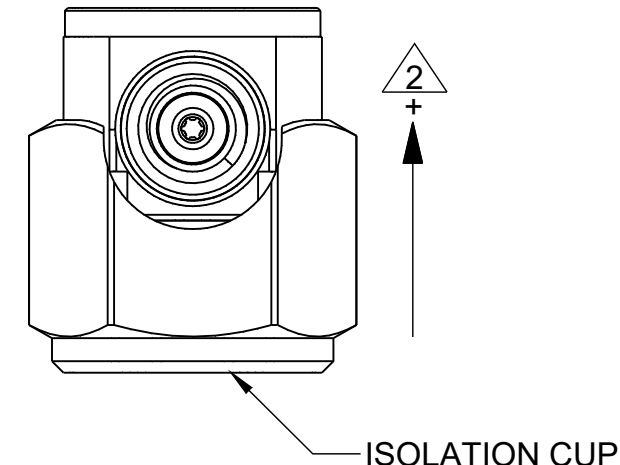
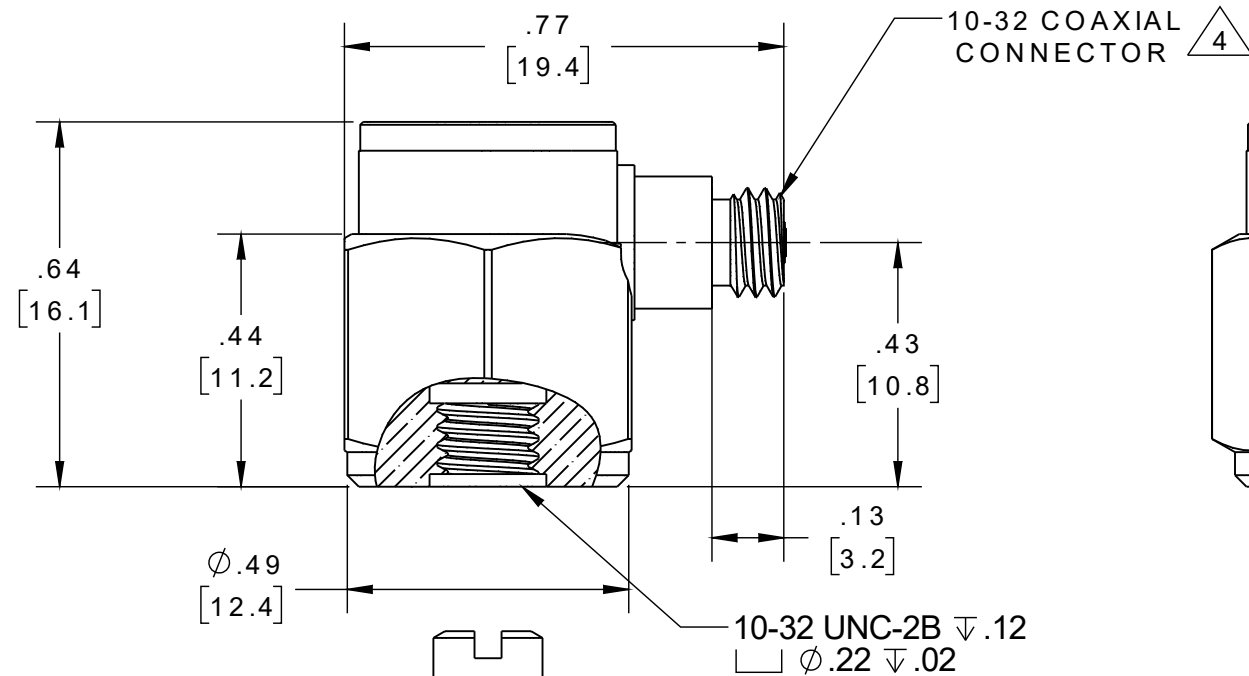
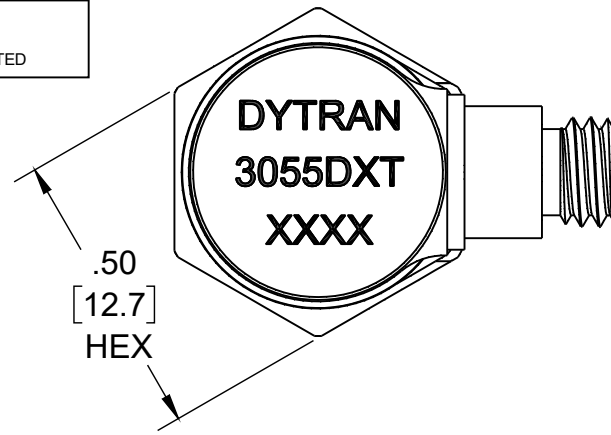

MOUNTING RECOMMENDATION:
 PREPARE A .55 [14] X .55 [14] MIN SURFACE,
 FLAT TO .001 TIR.
 TAP 10-32 UNF-2B x .15 [3.8] MIN.
 MOUNTING TORQUE: 10-12 Lb-in.

5. OPERATING TEMPERATURE: -67 °F TO +320 °F [-55 °C TO +160 °C]
 TEDS OPERATING TEMPERATURE: -40 °F TO +185 °F [-40 °C TO +85 °C]

4. MATES WITH DYTRAN 6010AXX OR 6011AXX CABLE (XX=LENGTH IS FEET).

3. WEIGHT: 10 GRAMS, MAX.

2. ARROW INDICATES ACCELERATION DIRECTION FOR POSITIVE OUTPUT.

1. MATERIAL: TITANIUM ALLOY

NOTES: UNLESS OTHERWISE SPECIFIED

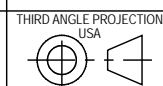
UNLESS OTHERWISE SPECIFIED: INTERPRET DIM & TOL PER ASME Y14.5M - 1994. REMOVE BURRS. COUNTERSINK INTERNAL THDS 90° TO MAJOR DIA. CHAM EXT THDS 45° TO MINOR DIA. THD LENGTHS AND DEPTHS ARE FOR MIN FULL THDS. DIMENSIONS APPLY AFTER FINISHING.		UNLESS OTHERWISE SPECIFIED: DIMENSIONS ARE IN INCHES. DIMENSIONS IN BRACKETS [] ARE IN MILLIMETERS TOLERANCES ARE:		 Chatsworth, CA	
DECIMALS .XX ±.03 .XXX ±.010	METRIC .X ±.08 .XX ±0.25	ANGLES ±1°		TITLE: OUTLINE/INSTALLATION, SINGLE AXIS ACCELEROMETER, 320F, ISOLATED, TEDS, 3055D7T SERIES	
APPROVALS		DATE		SIZE B CAGE CODE 2W033 DWG NO 127-3055D7T REV	
ORIG	KG	09/21/20		SCALE: 3:1 SHEET 1 OF 1	
CHK					
APP					
DO NOT SCALE DRAWING					
ALL MACHINED SURFACES. TOTAL RUNOUT WITHIN .005. BREAK SHARP EDGES .005 TO .010. MACHINED FILLET RADII .005 TO .015. WELDING SYMBOLS PER AWS A2.4. ABBREVIATIONS PER MIL-STD-12.					

Model Number 3055D13T	PERFORMANCE SPECIFICATIONS	DOC NO PS3055D13T
---------------------------------	-----------------------------------	-----------------------------

IEPE ACCELEROMETER

REV B, ECN 16090, 03/02/21



- **-67 °F TO +325°F OPERATION**
- **BASE ISOLATED**
- **IDEAL LOW FREQUENCY RESPONSE**
- **TEDS FEATURE**

This family also includes:

Model	Sensitivity (mV/g)	Frequency Response, ±10% (Hz)	Time Constant (Sec)	Operating Temp (°F)
3055D7T	100	1 to 10000	0.5 to 1.5	-67 to +325
3055D8T	50	1 to 10000	0.5 to 1.5	-67 to +325
3055D9T	20	1 to 10000	0.5 to 1.5	-67 to +325
3055D10T	10	1 to 10000	0.5 to 1.5	-67 to +325
3055D14T	500	1 to 10000	0.5 to 1.5	-67 to +325

PHYSICAL
 Weight
 Connector Type
 Mounting Provision
 Material, Housing/Connector
 Sensing Element
 Element Style

ENGLISH		SI	
0.35	oz	10	grams
10-32		10-32	
10-32 Tapped hole		10-32 Tapped hole	
Titanium		Titanium	
Ceramic		Ceramic	
Planar Shear		Planar Shear	

PERFORMANCE
 Sensitivity, ± 5% [2]
 Range for ± 5 Volts Output
 Frequency Response, ± 5%
 Frequency Response, ± 10%
 Resonant Frequency
 Broad Band Resolution
 Linearity [3]
 Maximum Transverse sensitivity
 Strain Sensitivity @ 250µε

200	mV/g	20	mV/m/s ²
25	g pk	245	m/s ² pk
1 to 5000	Hz	1 to 5000	Hz
1 to 10000	Hz	1 to 10000	Hz
> 36	kHz	> 36	kHz
0.0003	g RMS	0.003	m/s ² RMS
± 1	% F.S.	± 1	% F.S.
5	%	5	%
0.002	g/µε	0.02	m/s ² /µε

ENVIRONMENTAL
 Maximum Shock
 Temperature Range
 TEDS Operating Temperature Range
 Seal

±2,000	g pk	19620	m/s ² pk
-67 to +325	°F	-55 to +163	°C
-40 to +185	°F	-40 to +85	°C
Hermetic		Hermetic	

ELECTRICAL
 Supply Current Range [4]
 Compliance Voltage Range
 Output Impedence, Typ
 Bias Voltage
 Discharge Time Constant
 Electrical Isolation
 TEDS Feature

2 to 20	mA	2 to 20	mA
+18 to +30	Volts	+18 to +30	Volts
100	Ω	100	Ω
+10 to +13	VDC	+10 to +13	VDC
0.5 to 1.5	Sec	0.5 to 1.5	Sec
10	GΩ, min	10	GΩ, min
IEEE 1451.4		IEEE 1451.4	

Refer to the performance specifications of the products in this family for detailed description

Supplied Accessories:

- 1) Accredited calibration certificate (ISO 17025)
- 2) Model 6200 mounting stud, qty 1

Notes:

- [1] All specifications are at room temperature unless otherwise specified.
 - [2] Measured at 100Hz, 1 g RMS per ISA RP 37.2.
 - [3] Measure using zero-based straight line method, % of F.S. or any lesser range.
 - [4] Do not apply power to this system without current limiting, 20 mA MAX. To do so will destroy the IC charge amplifier.
 - [5] In the interest of constant product improvement, we reserve the right to change specifications without notice.
- It is the customer's responsibility to validate that a particular product with the properties described in the product specification is suitable for use in a particular application. Parameters provided in datasheets and / or specifications may vary in different applications and performance may vary over time. All operating parameters, including typical parameters, must be validated for each customer application by the customer's technical experts.

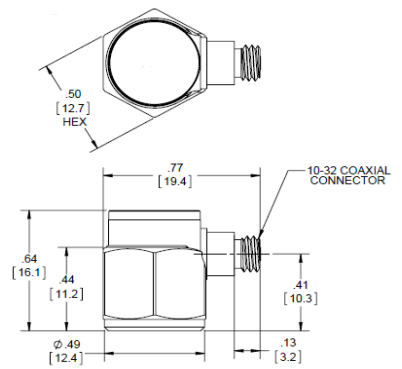
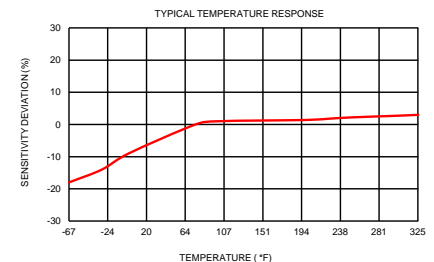
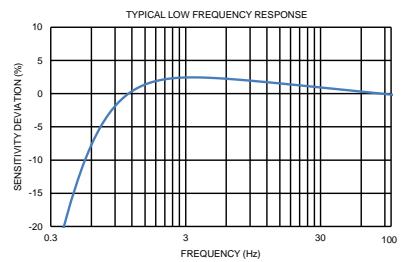

Units on the line drawing are in inches, units in brackets are in millimeters. Refer to 127-3055D7T for more information.



21592 Marilla Street, Chatsworth, California 91311 Phone: 818.700.7818 Fax: 818.698.0362 www.dytran.com
 For permission to reprint this content, please contact info@dytran.com